

Doulton®

Ultracarb

Ceramic Filter Cartridges

Doulton® has been a leading name in drinking water filtration for over 150 years.

Doulton® ceramic elements are now available in a range of standard cartridge formats which bring the quality associated with the Doulton® name to the general filtration market.

Ultracarb

Features

- Fits industry standard 10" and 20" filter housings
- Three filtration stages within a single cartridge
- Filtration efficiency of > 99.99% at 0.9 micron
- Filtration efficiency of > 98% at 0.2 micron
- Highly efficient bacteriological filtration
- Tested with live *Cryptosporidium* to a removal efficiency >99.9999%
- Ideal for R O guard and post filtration
- Complimentary to UV systems
- High levels of Chlorine and organics removal
- Lead and other heavy metal reduction



FILTERED
AND TREATED
WATER

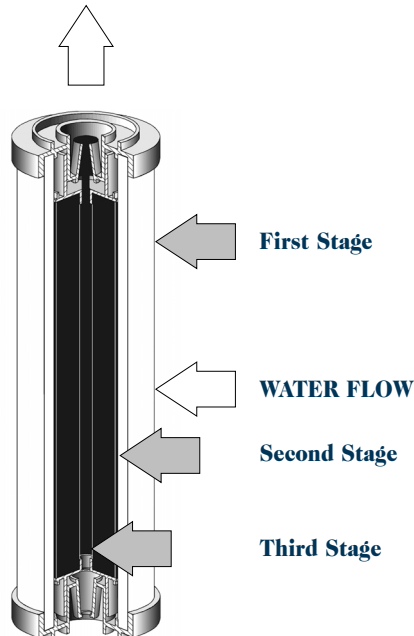

Ultracarb Cartridges

The Doulton Ultracarb is a three stage cartridge combining the highly efficient filtration properties of ceramic with the enhanced water treatment properties of activated carbon and the heavy metal reduction capabilities of ion exchange media.

First Stage

The first stage consists of Doulton Sterasyl® ceramic which provides genuine sub micron filtration. The cartridge reduces fine particulate matter, bacteria, cysts and turbidity. The incorporation of silver locked within the ceramic structure gives enhanced bacteriostatic and self sterilising properties.

Second Stage

An inner core of activated carbon block removes chlorine and organic compounds.

Third Stage

Ion exchange resin reduces Lead and other heavy metals.

Doulton®

Filtration Data Sheet

Filtration Efficiency

Absolute filtration rating	(defined as > 99.99%)	0.9 micron
Nominal filtration rating	(defined as 99.9%)	0.5 - 0.8 micron
% Bacteria removal	E.coli	> 99.99%
	Vibrio Cholera	> 99.99%
	Shigella	> 99.999%
% Cyst removal	Salmonella Typhi	> 99.999%
	Klebsiella Terrigena	> 99.99%
% Cyst removal	Cryptosporidium	> 99.999%
	Giardia	> 99.999%

20 Inch Filter Housings

Ultracarb Imperial (2 3/4") Filter cartridges can be supplied with a second adaptor cartridge to allow fitting in 20 inch filter housings. Due to slight variations in housing design, please state housing manufacturer when ordering.

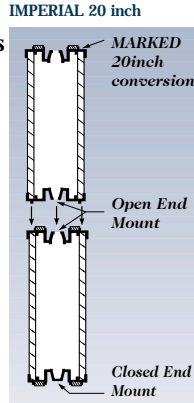

Cartridge Dimensions

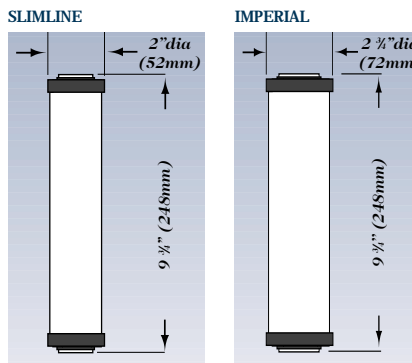

Product Specification

Working temperature range	5 - 38°C
Working pH range	5.5 - 9.5
Minimum working pressure	10 psi
Maximum working pressure	125 psi

Cartridge Shipping Specification

	Individual cartridge weight	Quantity per outer carton	Outer carton gross weight
Slimline 9 1/4 x 2"	0.3 kg	25	9 kg
Imperial 9 1/4 x 2 3/4"	0.55 kg	9	7 kg

Standard carton size 33 x 33 x 34 cm

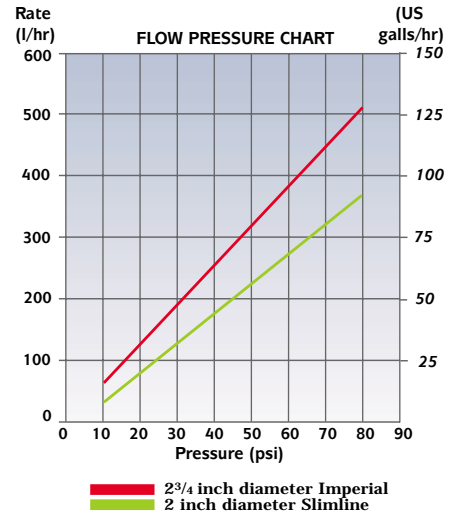

Chlorine Reduction (@ 2ppm challenge)

	Volume capacity @>97% removal efficiency	
	Litres	US Gallons
Slimline 9 1/4 x 2" (tested @ 1.7 L/min flow rate)	4000	1000
Imperial 9 1/4 x 2 3/4" (tested @ 3.8 L/min flow rate)	8000	2000

Lead Reduction (@ 150ppb challenge)

	Volume capacity @>98% removal efficiency	
	Litres	US Gallons
Slimline 9 1/4 x 2" (tested @ 1.7 L/min flow rate)	4000	1000
Imperial 9 1/4 x 2 3/4" (tested @ 3.8 L/min flow rate)	8000	2000

Trace Organics Removal

Insecticides	Lindane @ 0.1 ppb presence	> 85%
Herbicides	Atrazine @ 1.2 ppb presence	> 85%
Phenols	TCP @ 1.2 ppb presence	> 50%
Polyaromatic Hydrocarbons	PAH's @ 0.2 ppb presence	> 95%
Trihalomethanes	Chloroform @ 150 ppb presence	> 50%

(3000 litre challenge).

Due to a policy of continuing product development Fairey Industrial Ceramics Limited reserves the right to change any information without prior notice.

Doulton® water filters are manufactured by Fairey Industrial Ceramics Ltd

Doulton® and Sterasyl® are registered trademarks of which Fairey Industrial Ceramics Limited is an authorised user.



BS EN ISO 9002: 1994
Certificate Number: 90082



Distributed by: Eco Systems Int'l LLC